



TRIFLEX® Windows

Piping Stress Analysis Software

TRIFLEX®, a well-known name in piping stress analysis since 1971, provides piping stress analysts with an easy-to-use program to quickly and accurately analyze piping systems for the effects of pressure, temperature, weight, and other static loads as well as a variety of dynamic loading conditions.

TRIFLEX® has been successfully used to analyze piping systems from the simplest to the extremely complex and the accuracy of the results has been documented.

TRIFLEX® is truly unique. When users compare TRIFLEX® to other programs that they have used, they say that TRIFLEX® eliminates the need for a calculator to enter the data. TRIFLEX® accepts data in the format that users want to enter it and provides extensive user flexibility.

TRIFLEX® has been a leader in the implementation of innovation for years. TRIFLEX® produces complete results that document the behavior of a piping system and associated structural members in accordance with industry accepted codes and standards throughout the world.

Designing a new piping system

You can easily download GPS data or piping data from a 3-D CAD system directly into TRIFLEX® or you can quickly and efficiently build a piping model using the logical data dialogs provided by TRIFLEX®.

Analyzing or revamping an existing piping system

You can easily load a previously entered TRIFLEX® piping model and modify the piping model to reflect different design conditions or a different piping configuration.

With TRIFLEX®, you can produce more piping analyses in a shorter time with fewer errors and less frustration.

TRIFLEX® Windows

Find out why TRIFLEX® users are so loyal!

Since its introduction in 1971, TRIFLEX® has been extensively utilized by numerous companies and individual consultants around the world and has been the piping stress analysis program of choice for discriminating piping stress engineers throughout the world. There are numerous reasons for the success of TRIFLEX® including:

Ease of Use

TRIFLEX® is comprised of logically organized dialogs with linked extremely realistic 3-D graphics. Detailed user documentation as well as numerous "How To" PowerPoint presentations guide users through the use of TRIFLEX® when more than intuition is required. Extensive data checking is built into TRIFLEX® and user friendly data verification tools are provided to enable users to quickly perform additional checks. Users say that TRIFLEX® eliminates the need for a calculator and a scratch pad that other piping stress analysis programs require.

Proven Track Record

Since its introduction in 1971 and through all the various stages of development and through the transitions from the mainframe computers to mini-computers to the Microsoft DOS environment and finally the Microsoft Windows environment, TRIFLEX® has proven to be extremely stable

and reliable.

Quality Assurance

PipingSolutions, Inc., as a corporation, is committed to developing state of the art, high quality engineering software. PipingSolutions' performs extensive tests on all of our software, including TRIFLEX®. Stringent quality assurance (QA) standards are adhered to on each and every release of our software.

Widely Used & Accepted

TRIFLEX® is well-known and accepted as a reliable piping stress analysis tool throughout the oil & gas offshore and onshore, power, chemical,

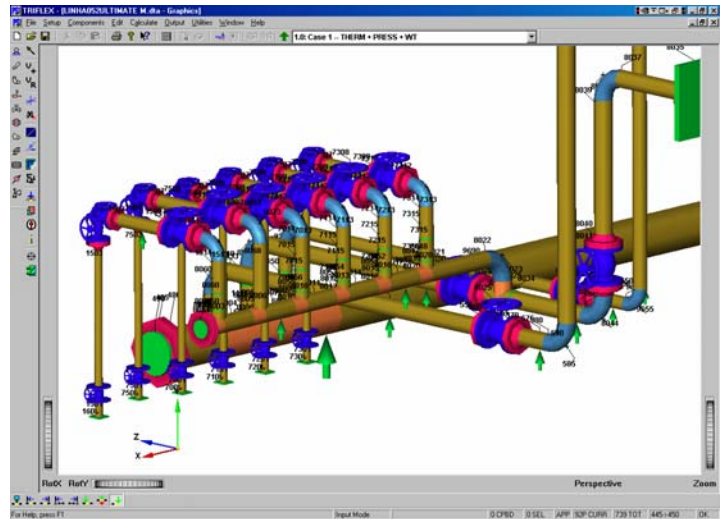

pulp and paper, utility, shipbuilding and pharmaceutical industries as well as in the engineering firms that serve them.

TRIFLEX® is the leader for the offshore and onshore oil & gas market.

Innovative Leadership

TRIFLEX® has frequently led the competition in the development of new and innovative technical capabilities and user conveniences. For instance, the 3-D graphics that TRIFLEX® offers has been the state of the art that all others try to match.

Continuing Development, Enhancement & Integration

Over the past thirty-five (35) years, PipingSolutions has continually invested in improving our software. We have committed large amounts of resources to insure that TRIFLEX® operates in the proper computer environment and has the technical capabilities and features that our TRIFLEX® users require. As technology and computer environments have changed, PipingSolutions has responded. As other software has been developed by other vendors for related functions, PipingSolutions has sought to develop interfaces with these software products. We are committed to integrating our software with related programs. PipingSolutions invites users to provide recommendations and input in the further growth of TRIFLEX®. We listen to our users and we respond with the features and capabilities they want.

Technical Support

Experienced piping stress analysts and developers of TRIFLEX® field users' inquiries and offer answers, options and recommendations in a timely and responsible manner. Since PipingSolutions also offers its services performing piping stress analysis, our piping stress analysts find

themselves being in the same situation as our TRIFLEX® users. Being on both sides of the technical support issue gives our staff a unique appreciation of the needs of our users.

Established Company

In 1999, PipingSolutions was established from the Engineering Software and Consulting Division of AAA Technology. In 1971, AAA Technology was established with an Engineering Software and Consulting Division and a Manufacturing Division. Prior to 1999, TRIFLEX® and all the related technical activities were operated as the Engineering Software and Consulting Division of AAA Technology. This means that the company that has developed and is continuing to develop TRIFLEX® is thirty-five (35) years old. The founder of the company is still with the company. Nor-Par has been the Distributor of TRIFLEX since 1984. That is stability!

Data Entry & Modeling Capabilities

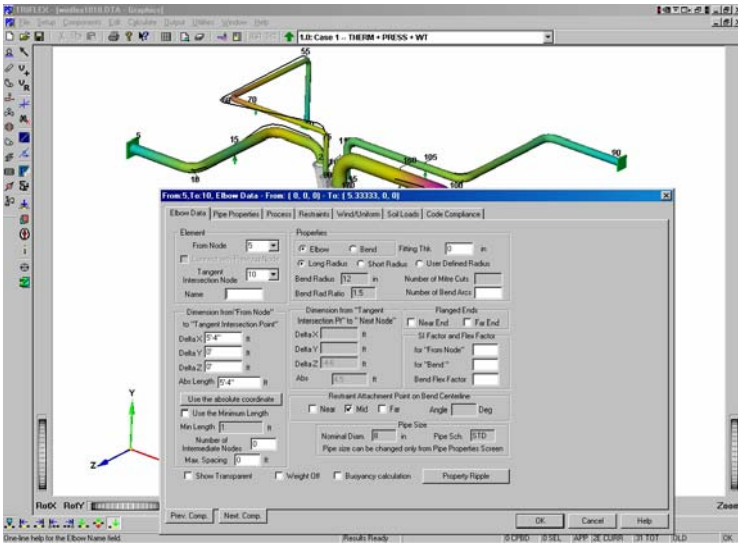

TRIFLEX® data entry capabilities have defined the standard for the way discriminating piping stress engineers approach piping system stiffness analysis. The intuitive manner in which TRIFLEX® is organized enables users to construct piping models faster and with fewer errors than with competing programs. With the tremendous flexibility provided by TRIFLEX®, the complexity of data entry is dramatically reduced as is the time required to construct each piping model. TRIFLEX® offers logically organized data entry dialogs that speed data entry and don't require digging through layers of hidden dialogs to find where data is to be entered. Given all the required data, piping models can be constructed in a short period of time. Extensive error checking is performed by TRIFLEX® as the piping model is constructed. If the model is not logical, TRIFLEX® will not pass it. To enable the user to further verify the integrity and validity of the data entered, TRIFLEX® provides numerous graphical data checking tools that are very easy to use.

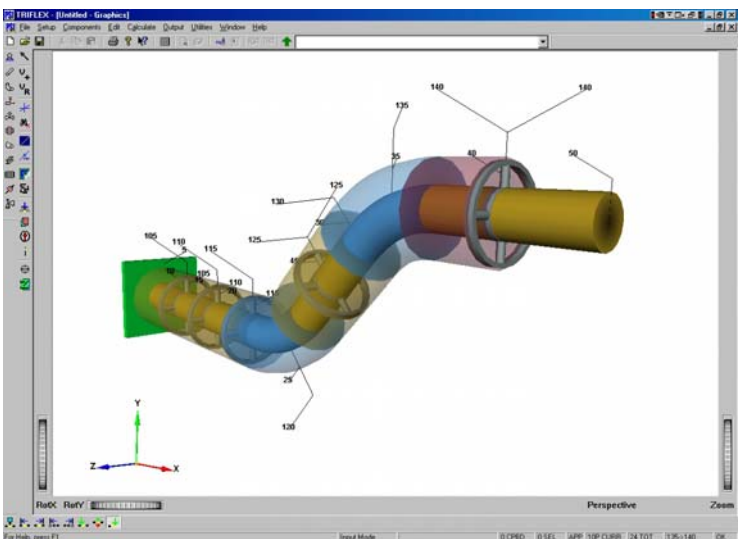

Data entry and modeling capabilities of TRIFLEX® include: Interactive Graphics

With TRIFLEX®, you have the ability to walk through and around your piping model at will. You can pan and rotate your piping model at will. You can zoom in or out at will as well and you can ask TRIFLEX® to hold any desired point in the piping model at the center of the screen. Want to look at two piping models in parallel windows and make comparisons? No problem for TRIFLEX®. TRIFLEX® provides users the ability to view piping in a single line representation or as a wire frame or as a rendered cylindrical shape. TRIFLEX® also provides the user with the ability to selectively cause segments of piping to be shown as translucent therefore enabling jacketed piping to be logically displayed.

User Documentation, On-Line Help & PowerPoint How To's

With TRIFLEX®, you have extensive, detailed user documentation as part of the TRIFLEX® installation. It all provided in PDF format and you can display chapter by chapter at will. On-line help is also provided to give field by field guidance for data entry. Further, PowerPoint Presentations are provided on PipingSolutions' website and are updated frequently in order to provide you the latest guidance to the use of TRIFLEX® to model virtually all possible piping situations.

Extensive Selection of Boundary Conditions Available

TRIFLEX® provides an extensive range of boundary conditions for the user to select from as follows:

Anchor types offered:

- Anchors with displacements
- Anchors without displacements
- Anchors with stiffnesses defined along some or all of the X, Y, Z axes
- Anchors with stiffnesses defined along some or all of the axes of a skewed axis system

Restraint types offered:

- Single or double acting translational
- Single or double acting rotational
- Translational with bi-linear stiffness
- Snubbers
- Guides and limit stops

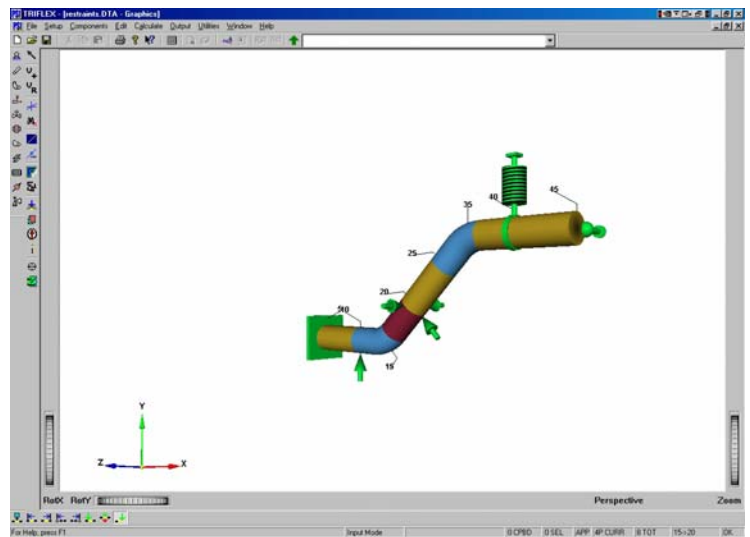

- Bottomed-out springs
- Gaps and support friction
- Release Elements for defining connectivity between two nodes in a piping system
- Soil friction
- Soil springs with multiple stiffnesses versus deflection

Loading types offered:

- Concentrated forces and moments
- Uniform Loads
- Automatically calculated Loadings
- Specified movements and rotations

Extensive Piping Databases

TRIFLEX® provides comprehensive databases for pipe diameters and wall thicknesses, flanges, valves, pressure relief valves, insulation, FRP/GRP material properties, modulus of elasticity, expansion coefficient and material properties with temperature dependent allowable stresses. The valve and flange databases include built-in length and weight data. TRIFLEX® also provides users the ability to add their own data to the database or to build their own database.

Structural Steel Database

TRIFLEX® provides the AISC structural steel database of structural properties and enables users to easily enter and orientate the structural members at will. TRIFLEX® accurately simulates structural members and provides deflections as well as forces and moments. Stresses calculated in accordance with the AISC will be computed by TRIFLEX® prior to the middle of 2006.

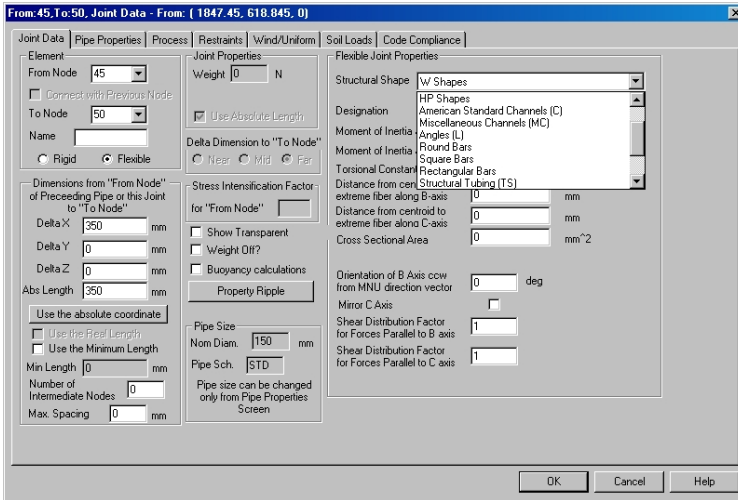

Inheritance

TRIFLEX® enables users to enter data only once; the entered properties will be inherited on each subsequent component until the User enters new properties. This feature makes entering the data for a typical piping system very straight forward and quick while reducing data entry errors.

Rippling

TRIFLEX® enables users to make revisions to existing piping models very quickly and easily. Edits can be easily made to one component at a time or to a sequence of components. Edits can be easily made to all or to selected data with a single edit. Selected data can be edited easily on all components that are similar, for instance, valves, or flanges or pipe segments, etc. Selected data can be edited easily on all components that have similar properties, for instance, temperature or pressure or all components with a specific thickness of insulation or all elbows and there are many more easy to use selection/edit options available in TRIFLEX®.

Block Operations for Editing Data

TRIFLEX® provides users with block editing features such as Copy, Flip, Paste, Delete, Undo, Redo, Renumber and Merge. Users can perform these operations in spread sheet mode or graphically. The graphical block operations enable the user to immediately see the operation without requiring other steps to see the results of the operation. Most other programs don't offer this tremendous graphical feature.

FRP/GRP (Fiberglass) Pipe Capabilities

TRIFLEX® provides users with the criteria of two piping codes specifically for fiberglass reinforced plastic pipe plus vendors' data to assist users in modeling FRP/GRP pipe as well as guidelines for evaluating the results.

Expansion Joint Modeling

Enables users to easily model single expansion joints as well as expansion joint assemblies with parameters taken directly from expansion joint manufacturers' catalogs. TRIFLEX® provides users the ability to accurately model expansion joints.

Other Input & Modeling Capabilities Include:

- Reducer Component automates the entry of Reducer geometry, even if skewed

- Cold spring (cut short and cut long) can be entered directly
- Bend Flexibility Factors automatically calculated
- Bend Stress Intensification Factors (SIF's) automatically calculated
- Branch Intersection Stress Intensification Factor (SIF's) automatically calculated
- Automatic generation of soil restraint model for buried pipelines according to B31.1, App. VII.

Piping Codes Included in TRIFLEX®

- **B31.1** ASME Power Piping Code
- **B31.3** ASME Process Piping Code
- **B31.4** ASME Pipeline Transportation Systems for Liquid Hydrocarbons and Other Liquid Codes
- **B31.5** ASME Refrigeration Piping and Heat Transfer Component Code
- **B31.8** ASME Gas Transmission & Distribution Systems Code (DOT Guidelines) (including Chapter VIII for Offshore)
- **NAVY** - US Navy - General Specifications for Ships, Section 505
- **CLAS2** - ASME Section III - Division 1 (Subsection NC) - Class 2
- **CLAS3** - ASME Section III - Division 1 (Subsection ND) - Class 3
- **SPC1** - Swedish Piping Code (Method 1, Section 9.4)
- **SPC2** - Swedish Piping Code (Method 2, Section 9.5)
- **TBK** - Norwegian General Rules for Piping Systems (Annex D - Alternative Method)
- **TBK5-6** - Norwegian General Rules for Piping Systems (Section 10.5)
- **DNV** (Det norske Veritas) - DnV for Submarine Pipeline Systems, 1981 and 1996

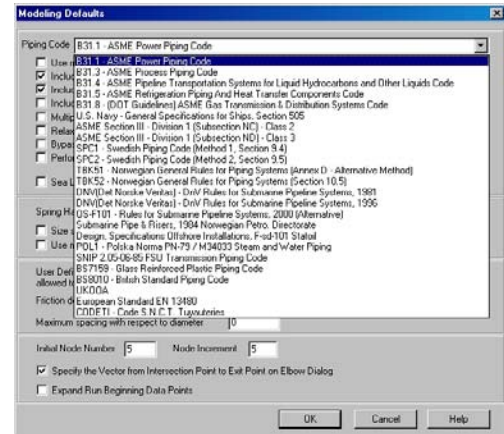

- **OS-F101** - Rules for Submarine Pipeline Systems, 2000 (Alternative)
- **NPD** - Submarine Pipe and Risers, 1984 Norwegian Petroleum Directorate
- **STOL** - Design Specifications, Offshore Installations F-sd-101 Statoil
- **POL1** - Polska Norma PN-79 / M34033 Steam and Water Piping
- **SNIP** - 2.05-06-85 FSU Transmission Piping Code
- **BS7159** - British Standard Code for Glass Reinforced Plastic Piping
- **BS8010** - British Standard Piping Code
- **UKOOA** - UK Offshore Operator Association
- **EURO** - European Standard EN 13480-3
- **CODETI** - French Piping Code

Static Analysis Capabilities

TRIFLEX® provides the user with the ability to fully describe in words the piping model for documentation purposes. Further TRIFLEX® provides the user with the ability to create an integrated Word document that is automatically saved with the TRIFLEX® DTA file. TRIFLEX® provides defaults for all basic options, but the user can selectively override any or all of them. TRIFLEX® provides, as a default, the recommended load cases necessary for a sequence of analyses to be performed by TRI-

FLEX[®] that will result in a piping code compliance report indicating whether the stress level in a piping system is within the selected piping code requirements. TRIFLEX[®] also provides the user with the ability to perform algebraic combinations of displacements, forces and stresses which gives users the ability to generate virtually any loading combination desired. This load combination capability is the most flexible in piping

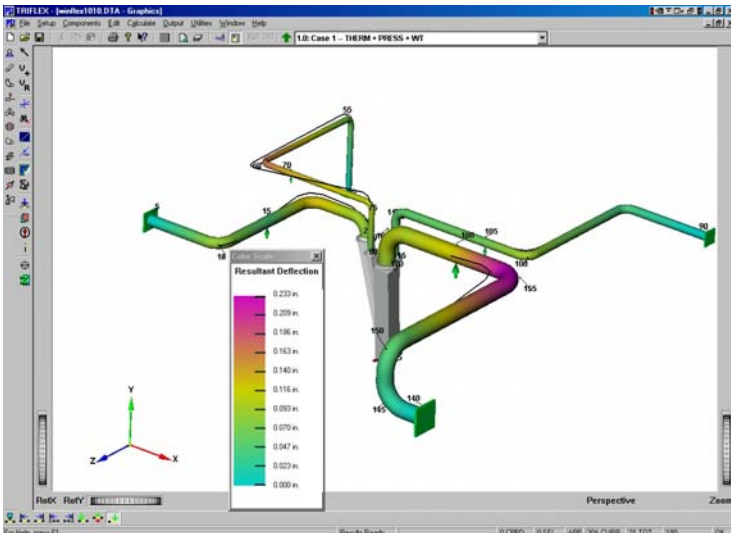

stress analysis software available today. TRIFLEX[®] provides unlimited load cases and unlimited load case combination capability. TRIFLEX[®] enables the user to analyze models consisting of both piping and structural components. The interaction of the piping and structural components can easily be viewed and measured. The deflected shape of the piping system is easily displayed graphically and the piping model with the deflected shape can be panned, rotated and zoomed at will. Single acting restraints are and always have been handled in code compliance calculations as recommended in the piping codes. The extensive load case combination capability enables users to control the static analysis process more selectively than any other software on the market today.

**Static analysis capabilities in TRIFLEX[®] include:
Extensive Spring Hanger Selection Capabilities**

When a desired manufacturer of spring hangers is selected by the user, TRIFLEX[®] automatically processes the necessary analyses to determine the operating load and the installed position to operating position travel. TRIFLEX[®] then determines the spring hanger size and series required and gives the user two options to select from, if available. TRIFLEX[®] provides the user with the ability to easily display the deflections for multiple selected load cases for each spring hanger.

Wind Load Generation

TRIFLEX[®] provides the user with the ability to define wind loads as a function of wind speed, pressure or load per unit length of the pipe. Projected surfaces are automatically computed and reduced loads are therefore automatically calculated.

Equipment Loading Compliance Report

TRIFLEX[®] provides users the ability to model the piping and the equipment in one analysis and to have TRIFLEX[®] automatically generate nozzle and casing loading compliance reports for the following standards:

- NEMA SM/23 for Steam Turbines
- API Std. 617 for Centrifugal Compressors
- API Std. 610 for Centrifugal pumps
- ROT User Customized Reports with vendor allowable loads

Flange Leakage Calculations

TRIFLEX[®] provides users the ability to perform leakage calculations for any selected point in a piping system. The leakage calculations are based upon the ANSI B16.5 ratings and an equation from the ASME Section III Code that converts piping loads and internal pressures into equivalent pressures which are then compared to the flange allowable pressures in accordance with the ANSI B16.5 Standard.

Nozzle Flexibilities and Stresses

TRIFLEX[®] provides users the ability to calculate nozzle flexibilities in accordance with the Welding Research Council (WRC) Bulletin 297 as well as entering flexibilities computed based on any other guideline.

WERCO[™], the companion program to TRIFLEX[®], can easily be used to compute stresses in nozzle shells and the intersection point. WERCO[™] computes stresses based upon the rules set forth in the WRC 107 and WRC 297 Bulletins.

Fatigue Analysis and Cumulative Usage Report

TRIFLEX[®] provides users the ability to calculate the remaining life in a piping system based on material fatigue curve data from the ASME Section VIII, Division 1 Code and number of cycles entered by the user. The cumulative usage report provides a total usage factor taking into consideration all fatigue cases defined by the user.

Offshore Piping Analysis

Based upon the entered density of the surrounding seawater, TRIFLEX[®] automatically calculates the external hydrostatic pressure applied on the pipe. Further TRIFLEX[®] provides users the ability to enter the hydrodynamic effects of ocean waves and ocean currents on selected components in a piping system.

Dynamic Analysis Capabilities

TRIFLEX[®] provides users the ability to perform detailed dynamic analyses and to consider the results of the dynamic analyses as the occasional stresses in a piping code compliance analysis. The dynamic analysis capabilities offered by TRIFLEX[®] are Response Spectrum Analysis and Time History Analysis. Prior to performing a dynamic analysis, TRIFLEX[®] generates mode shapes and natural frequencies for a piping system. Then the user may conduct a Response Spectrum Analysis and Time History Analysis depending upon the loadings to be applied.

**Dynamic analysis capabilities in TRIFLEX[®] include:
Mode Shape and Natural Frequency Generation**

TRIFLEX[®] generates the mode shapes and natural frequencies for a piping system. TRIFLEX[®] enables users to view each mode shape graphically. Knowing the natural frequencies of the connected equipment and the piping system, a user can easily avoid most inherent piping vibration problems.

Response Spectrum Analysis

TRIFLEX[®] provides users with two methods to generate response spectra or the user may construct custom spectra for use in an analysis. With TRIFLEX[®], a user can enter as many as three spectra to be applied to a piping system in one analysis. The results of such a spectral analysis can be stored in a load case and considered as occasional loads and stresses in a code compliance analysis. TRIFLEX[®] provides the ability to store, recall and edit specific spectral definitions as well as the ability to view each spectrum graphically.

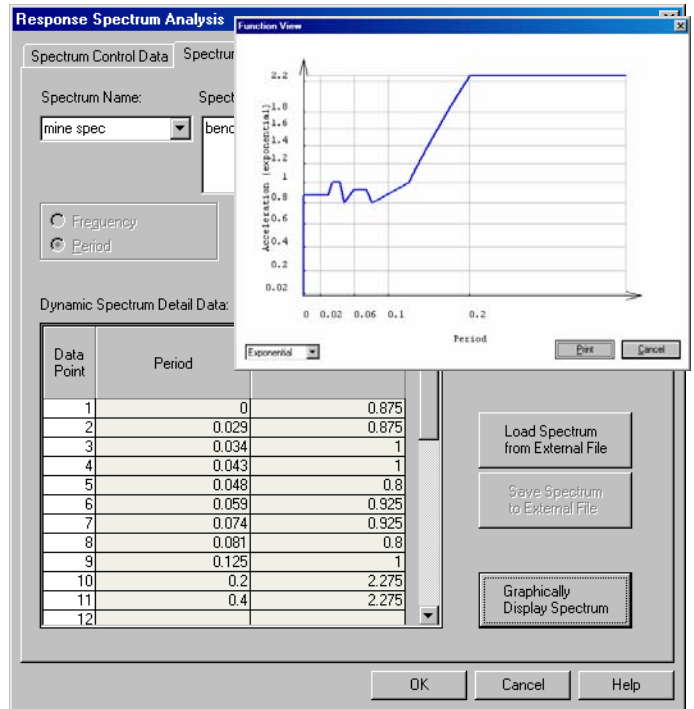

Time History Analysis

TRIFLEX® provides users the ability to simulate the application of loadings on a piping system as a function of time and to view the resulting reaction of the piping system as a function of time. Employing the Time History method, TRIFLEX® provides users the ability to perform equip-

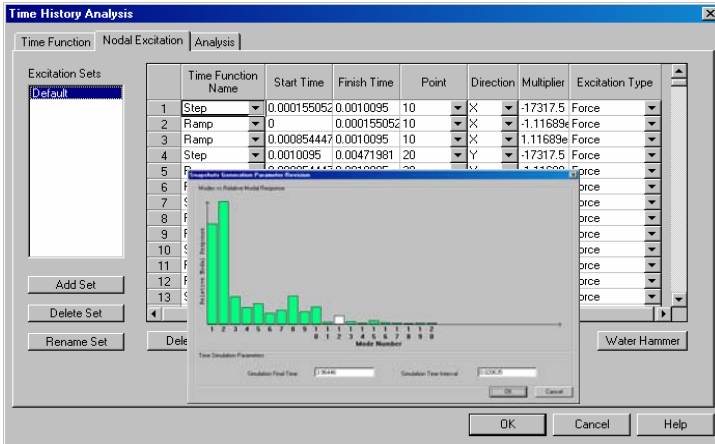

ment imbalance studies, water hammer studies, steam hammer studies, relief valve release studies, transient flow studies as well as other time dependent studies. For non-branching piping systems subject to water hammer loading, TRIFLEX® calculates the forcing functions at significant piping system nodes along with the time of arrival at each node. This allows the user of TRIFLEX® to accurately simulate a water hammer event without requiring the use of any other software. Where more complex piping systems are being simulated for the effects of water hammer, time dependent load data can be generated using another program such as Pipenet Transient and the data can be imported directly by TRIFLEX® or the data can easily be entered manually using the user friendly data entry dialogs in TRIFLEX®. **Interface with PIPENET Transient available.**

The effect of the time variant function on the displacement of the system may then be displayed graphically in an animation sequence. The imposed loading has an effect on the piping system displacements, forces, moments and stresses, which may be viewed on a spreadsheet at each time increment or in tabular form for all time increments for each point in the piping system. The maximum of these system effects can be added onto the occasional loading for one or more case definitions and specified as the occasional load for a piping code compliance report.

Animation of Time History Analysis Results

TRIFLEX® provides users the ability to generate mode shapes and natural frequencies for a piping system and display them graphically. TRIFLEX® also enables users to generate time dependent animations of a piping system showing the displacement as a function of time. This feature enables users to better understand the effects of the dynamic loadings on the piping system.

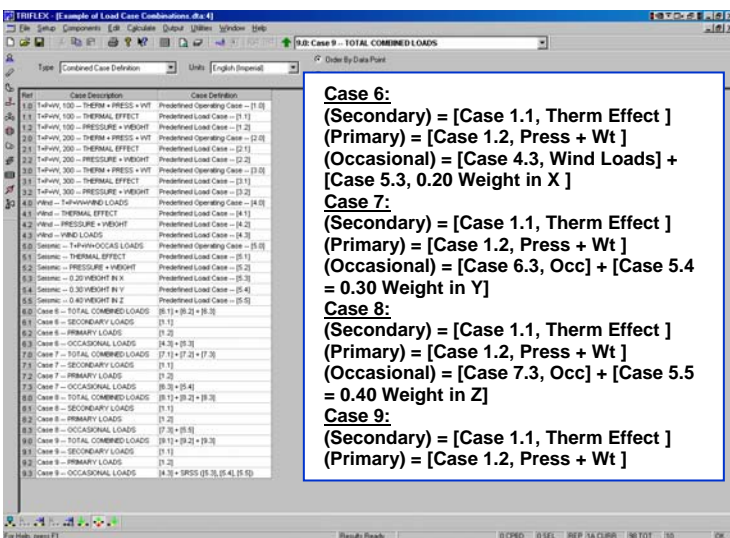

Load Case Combinations Available for Static and Dynamic Loads

TRIFLEX® provides users the ability to define any load case or combination of load cases as the primary, secondary or occasional component of a new load case. TRIFLEX® also enables users to combine any of these load cases using a variety of methods available in TRIFLEX®.

Output Capabilities

TRIFLEX® provides users with the most complete and flexible Output Reporting capabilities in the market. TRIFLEX® generates reports in spread sheet format that can be printed individually or in groups as desired by the user. The reports available include: Center of Gravity, Piping System Geometry, Piping System Properties, Piping System Weights,

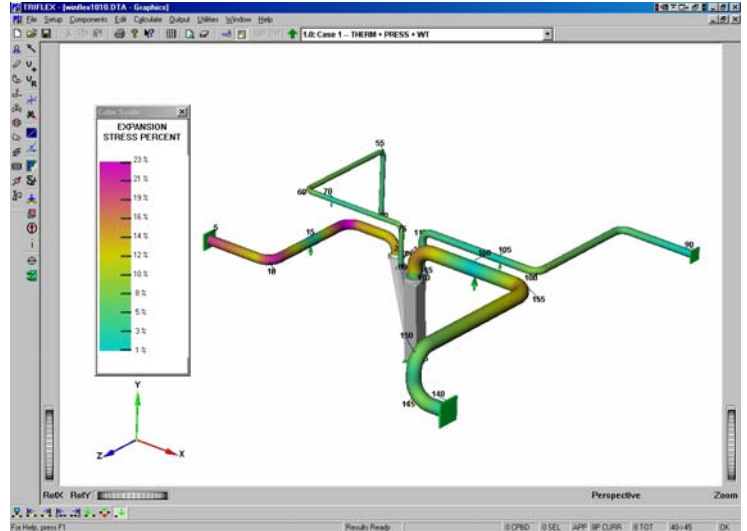

Anchor Description, Anchor Initial Translations and Rotations, Expansion Joint Description, Restraint Description, Axis Description, Piping System Movements, Local Movements, Anchor Movements, Restraint Movements, Expansion Joint Deflections and Rotations, Local Forces and

Date Point	Date Point Node Location	DESIGN WALL THICKNESS	DESIGN MINIMUM THICKNESS	COMBINED STRESS ACTUAL	COMBINED STRESS ALLOWED	LONGITUDINAL STRESS ACTUAL	LONGITUDINAL STRESS ALLOWED	COMBINED STRESS ACTUAL vs ALLOWED	Date Sequence					
1	20	20	50000	0.50	1.00	1.00								
2	20	30	50000	0.50	1.00	1.00								
3	30	40	50000	0.50	1.00	1.00								
4	40	50	50000	0.50	1.00	1.00								
5	2250	Run/beg	0.500	0.443	40081	50000	89	49330	39000	103	6051	37440	18	2744
6	2400	Run/end	0.562	0.554	44882	50000	87	30643	39000	86	6033	37440	19	2720
7	3710	Run/end	0.625	0.490	41146	50000	79	34613	39000	80	6533	37440	17	641
8	4030	Run/end	0.500	0.369	32775	50000	63	12979	39000	33	19795	37440	83	487
9	2650	Run/end	0.625	0.396	32863	50000	63	22056	39000	64	7	37440	0	2227
10	2370	Bend	0.562	0.554	32187	50000	62	21288	39000	55	10906	37440	29	2677
11	2370	Bend/beg	0.562	0.554	30939	50000	59	20863	39000	54	10566	37440	27	2676
12	1700	Run/beg	0.500	0.443	30407	50000	58	20167	39000	72	2243	37440	6	2752
13	2370	Bend/end	0.562	0.554	28487	50000	57	20126	39000	52	1862	37440	25	2681
14	2390	Bend	0.562	0.554	29590	50000	57	18273	39000	49	10319	37440	26	2706
15	3600	Bend	0.625	0.490	29986	50000	57	17730	39000	45	12137	37440	32	793
16	2290	Run/end	0.625	0.554	29229	50000	56	21285	39000	54	8231	37440	21	2743
17	2390	Bend/beg	0.562	0.554	26707	50000	55	18903	39000	48	9604	37440	26	2705
18	3600	Bend/beg	0.625	0.490	26962	50000	55	17404	39000	45	12137	37440	30	792
19	2290	Run/end	0.625	0.554	26511	50000	55	20262	39000	65	3205	37440	9	2423
20	2550	Run/beg	0.625	0.396	20082	50000	54	26214	39000	67	1789	37440	5	1529
21	4600	Bend/end	0.625	0.554	27807	50000	53	27138	39000	70	669	37440	2	1602
22	3600	Bend/end	0.625	0.490	27410	50000	53	16786	39000	43	15645	37440	26	797
23	1930	Run/beg	0.625	0.490	27328	50000	53	20124	39000	52	7204	37440	19	502
24	2390	Bend/end	0.562	0.554	27211	50000	52	18474	39000	47	8737	37440	23	2710
25	3700	Bend	0.625	0.490	26960	50000	52	15443	39000	40	11367	37440	30	822
26	1930	Run/end	0.625	0.490	26340	50000	51	23247	39000	60	3093	37440	8	598
27	370	Run/end	0.500	1.003	26296	50000	51	26293	39000	67	3	37440	0	179
28	2440	Run/end	0.500	0.443	26124	50000	50	26679	39000	66	446	37440	1	2398
29	2390	Bend/Mid	0.625	0.554	25781	50000	50	22199	39000	57	3562	37440	10	2424
30	3700	Bend/beg	0.625	0.490	26103	50000	50	15262	39000	39	10851	37440	29	821
31	1210	Run/beg	0.625	0.490	25981	50000	50	27783	39000	56	3071	37440	6	640

Moments, System Forces and Moments, Anchor Forces and Moments, Restraint Forces and Moments, System Stresses – this load Case and Maximum System Values. Essentially all of the same reports are available in an ASCII format with similar report selection capability for multiple report printing.

Additional reports that are available for printing are: the Piping Code Compliance Report, the Spring Hanger Report, each of the Rotating Equipment Reports and the Flange Loading Report. The Piping Code Compliance Reports show all applicable data entered as well as the calculated values and the allowables taken from the applicable piping code based upon the temperature of the piping system in the analysis. Percentages are shown for all stresses computed when compared with the allowables taken from the piping code. When overstress conditions are found, these areas of the piping system are highlighted in the piping code compliance report.

Output reports can also be generated for selected portions of a piping system rather than the entire piping system and can be sorted by load case rather than by data point. The reports that may be viewed by load case include Anchor Movements and Forces, Restraint Movements and Forces, and Global Movements and Forces. These reports may include or exclude sub cases, and, should a dynamics time history case be available, they can give a detailed listing of all available items versus time. This capability is specifically used by pipe support engineers to document deflections, forces and moments at specific pipe support locations.

TRIFLEX[®] can export most tabular output reports to a Microsoft Excel spreadsheet with each report being written to a separate worksheet with the tab labeled to reflect the report on the worksheet. **Custom reports also in local languages easy to make.**

All output reports related to deflections, rotations, forces, moments and piping code stresses can be displayed graphically with color indicating the magnitude of the selected value and a color scale indicating magnitude versus color. Actual deflected shapes can be shown for a piping system and the X, Y and Z components of the deflected shapes can individually be shown, if desired. While any of these graphical representations are displayed, TRIFLEX[®] enables the user to rotate, pan and zoom the graphics displayed.

Data Import Capabilities

TRIFLEX[®] provides Users the ability to import data from a number of different programs used for constructing computer-based piping system models. The time required to construct TRIFLEX[®] piping models will be dramatically reduced when geometry, piping properties, process data and various loading data is imported from previously constructed CAD models. TRIFLEX[®] imports model data from the following 3-D CAD programs:

- PDS and SmartPlant by Intergraph *)
- PDMS by AVEVA *, **)
- CATIA by Dassault Systemes *, ***)
- PLANT 4D by CEA Systems *)
- CADPIPE by AEC Design Group *)
- AutoPlant and PlantSpace by Bentley Systems *)
- Dimension III by Calma *, ***)
- I-Sketch by Alias *)

*) Requires CAD Option **) Requires I-SKETCH and Nor-Par Smart Stress Iso ***) Requires interface from the CAD system vendor

TRIFLEX[®] imports model data from the following piping stress analysis program:

- Caesar II by Coade

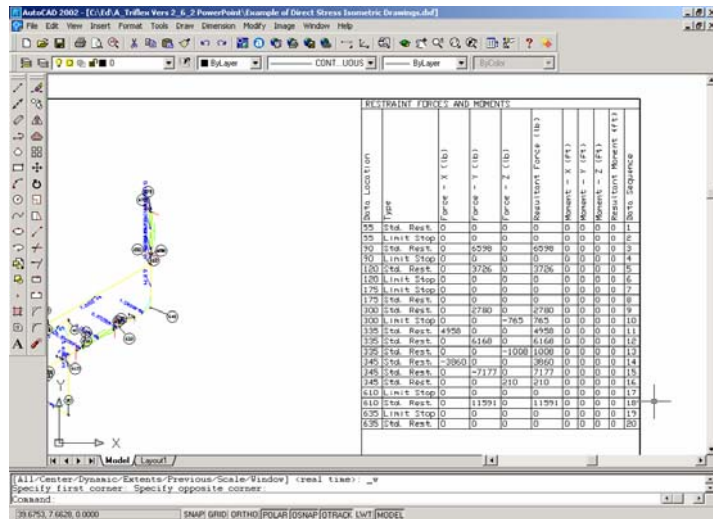

TRIFLEX[®] imports model geometry data from Excel files. This is specifically handy if geometric data is obtained via GPS devices or other devices that can generate spatial coordinates.

TRIFLEX[®] imports model loading data from the following transient flow program:

- PIPENET Transient by Sunrise Systems

TRIFLEX[®] has a data rich neutral data file format that has been developed to enable vendors of other software to easily develop complete data interfaces with TRIFLEX[®].

TRIFLEX[®] imports TRIFLEX[®] DOS keyword files and job files.

Data Export Capabilities

TRIFLEX[®] provides users the ability to export Stress Isometric Drawings in AutoCAD 3-D DXF files. The exported DXF files can include data on layers such as node identifiers, dimensions and selected output reports from selected Load Cases processed by TRIFLEX[®]. (Requires CAD Option)

TRIFLEX[®] can export to tab-delimited TXT files as well. This allows database applications such as Access or ORACLE to import the results directly from TRIFLEX[®] into their proprietary format (column header names are also exported).

TRIFLEX[®] can export most tabular (spreadsheet-based) output reports to Microsoft Excel spreadsheet with each report being written to a separate worksheet with the tab labeled to reflect the report on the worksheet.

TRIFLEX[®] exports TRIFLEX[®] DOS keyword files and job files. Graphics can be exported to high-quality image files in the JPEG, BMP and PS (PostScript) format. The resolution can be set dynamically so that the files may be used for poster printing.

Hardware/Software Requirements:

- Intel Pentium processor, AMD Sempron, Athlon or Turion processor (or equivalent)
- Microsoft Windows (2000, XP or Vista) Operating System
- Microsoft Word, Excel and Access (recommended to be able to use all capabilities of TRIFLEX[®])
- 128 Mbytes RAM (minimum) (256 Mbytes RAM or higher recommended)
- 30 Mbytes of disk space
- CD ROM Drive or Internet connection to download TRIFLEX[®]

TRIFLEX[®] Licenses

All TRIFLEX[®] licenses include the following:

- A CD containing a complete copy of the TRIFLEX[®] program – the options selected by the user will be enabled
- A complete copy of the User Manual on the CD
- One Activator allowing access to one copy of TRIFLEX[®] - *note that fully functional network versions of TRIFLEX[®] are available and in daily use around the world.*
- Access to the TRIFLEX[®] training center on the Nor-Par Website where numerous PowerPoint presentations are periodically made available for user guidance and training
- Periodic Technical Bulletins sent by e-mail
- Technical Support from Nor-Par via telephone, e-mail, and fax

Perpetual License from Nor-Par provides:

- Single User or Network License without limit on the number of uses or the time during which such uses may occur
- Annual maintenance, updates and support (MUS) for TRIFLEX[®] according to the MUS contract
- Eligibility for additional maintenance, updates and support (MUS) for TRIFLEX[®].

Annual Maintenance, Updates & Support provides:

- Maintenance, updates & technical support for TRIFLEX[®] according to the MUS contract. PipingSolutions and Nor-Par provide periodic releases of TRIFLEX[®] to incorporate corrections and new capabilities and features.

Rental provides:

- Single User or Network License copy usable for an agreed upon period of one month to one year
- Maintenance, updates and support (MUS) for TRIFLEX[®] during the period of the license

Limited Run (Pay-Per-Run) provides:

- Single User License copy with a limit on the number of actual analyses (100 Minimum) that can be processed
- Maintenance, updates and support (MUS) for TRIFLEX[®]
- Additional runs may be purchased over the telephone, fax or e-mail

Nor-Par a.s Nordstrandveien 76, 1164 Oslo Norway
Phone: +47 22286900 Fax: +47 22286981 e-mail: admin@norpar.com